

SCANIA



CONCRETE PUMP

BODYBUILDING MADE EASIER!

Tailormade for your application with best preparations available.

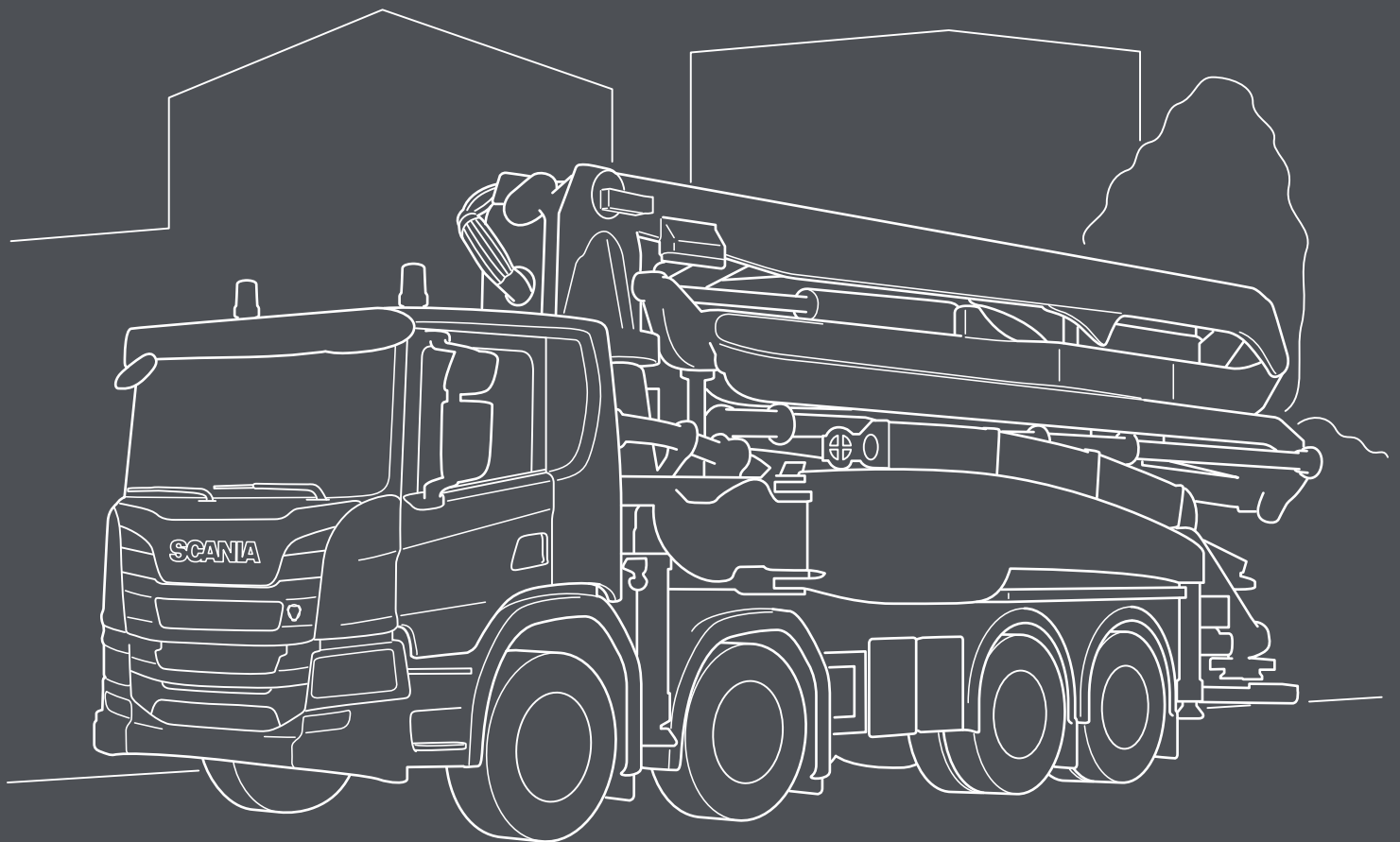

Concrete pump

Truck specification

Chassi: P 450 B8x4NZ

Cab: CP17L

Beacon FPC1330
Mounted on a robust aluminium bar, the rotating beacon supplies efficient warning light.

Bodybuilder tube across IP C*
All trucks are supplied with an empty tube inside the instrument panel, dedicated for the bodybuilder.

Remote controlled engine start FPC3313
Preparation for engine start (need BCI).

Engine hour meter FPC1356
The engine hour meter register the total operating hours of the engine.

Instrument panel control lights BB FPC3888
There are many options for the bodywork to provide the driver with information, 8 lamps, sound and display messages in the instrument cluster. The lamps can indicate with different colours.

Headlight protection FPC2021
The headlights are protected by a steel grille.

CAN switches FPC6793
Spaces in the instrument panel are reserved for extra switches that are programmed in the BCI control unit.

3x7 pole electrical preparation from cab FPC2411
Pre-routed cable harness from the bodywork's central electric unit that is terminated with a DIN connector on the frame under the cab. 1, 2 or 3 pieces with 7 poles in each (contains different types of 1,5mm², 2,5mm² and CAN cables).

BB electrical supply 150A continually, 250A max B*
All trucks are supplied with a dedicated electrical output, conveniently located behind the mudguard of the 1st front axle.

EG PTO preparation FPC3502
The electric preparation includes routed wiring for activation of an EG power take-off.

New routing air and electrical 2nd front axle D*
With the new design, Bodybuilder have much more clearance in this area.

Lowered steering linkage 2nd front axle D*
With the new design, Bodybuilder have much more clearance in this area.

***Always on truck**

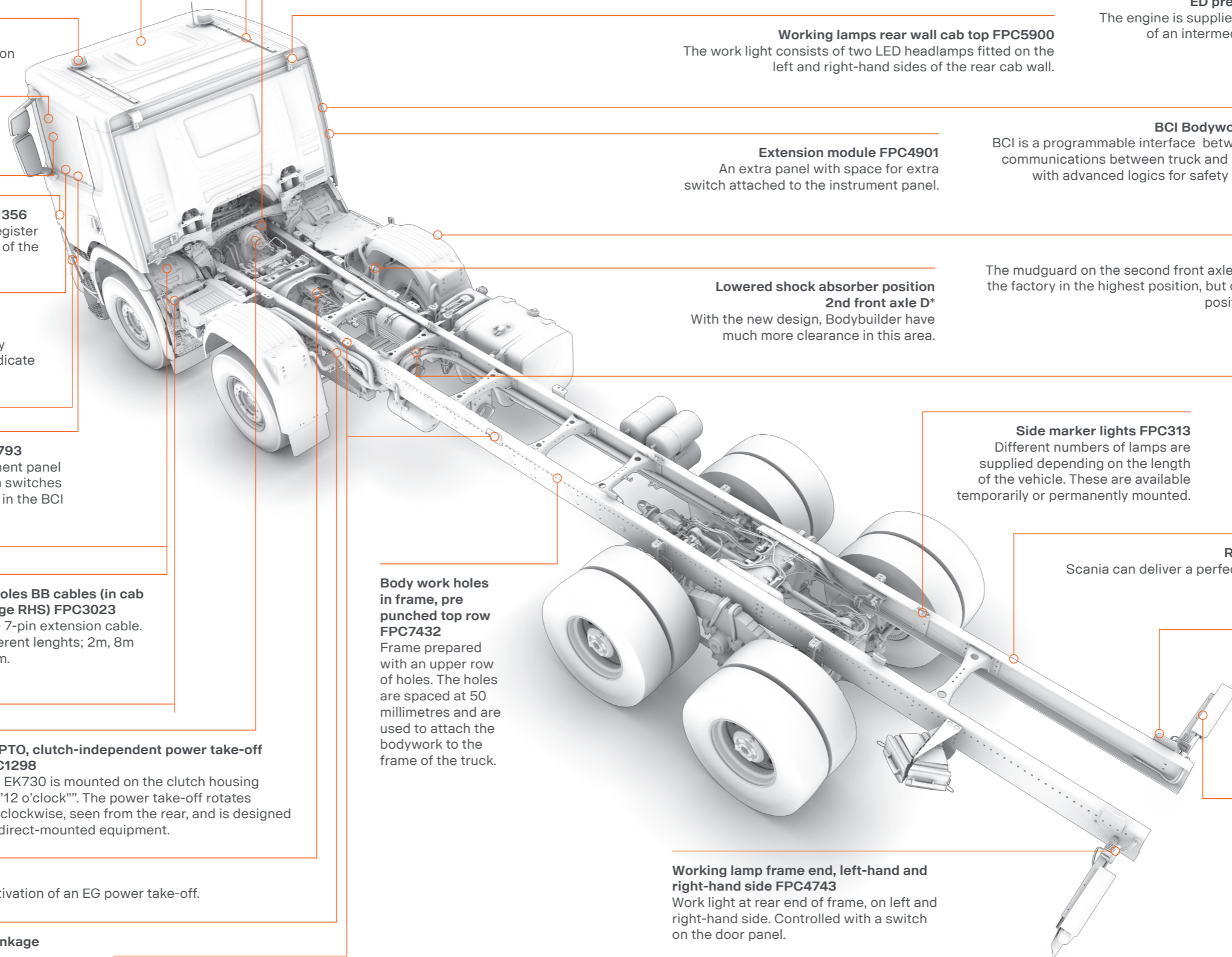

Cable harnesses in cab roof FPC3024
Extra harnesses for bodybuilder installed in cab roof.

Roof rails FPC1401
The roof rails are in aluminium which simplifies the fitting of an air deflector, roof rack and other extra equipment.

Working lamps rear wall cab top FPC5900
The work light consists of two LED headlamps fitted on the left and right-hand sides of the rear cab wall.

Extension module FPC4901
An extra panel with space for extra switch attached to the instrument panel.

Lowered shock absorber position 2nd front axle D*
With the new design, Bodybuilder have much more clearance in this area.

Body work holes in frame, pre punched top row FPC7432
Frame prepared with an upper row of holes. The holes are spaced at 50 millimetres and are used to attach the bodywork to the frame of the truck.

BB brackets (flexible/with holes/for welding) FPC3303, FPC3302
Scania can offer many different body attachment brackets to suit a variety of applications. The bodywork is bolted into the upper row of holes on the bracket.

ED preparation for hydraulic pump FPC4827
The engine is supplied prepared for power take-off. Consists of an intermediate gear which is fitted in the flywheel housing.

BCI Bodywork communication interface FPC5837
BCI is a programmable interface between the truck and bodywork facilitating communications between truck and bodywork. The BCI can be programmed with advanced logics for safety and other operational functionality in the bodywork.

Mudguards 2nd front axle FPC4050
The mudguard on the second front axle is height-adjustable. It is supplied from the factory in the highest position, but can be easily adjusted to three different positions to fit with the bodywork and tyres.

Side marker lights FPC313
Different numbers of lamps are supplied depending on the length of the vehicle. These are available temporarily or permanently mounted.

Air supply inside frame A*
A dedicated outlet for BB needs of air is included on every chassis. This is the one and only place allowed to connect air supply to bodywork.

Rear overhang in 10mm steps FPC1537
Scania can deliver a perfect adapted overhang to every bodywork within 10 mm steps.

BB brackets (flexible/with holes/for welding) FPC3412
Scania can offer many different body attachment brackets to suit a variety of applications. The bodywork is bolted into the upper row of holes on the bracket.

Tail lamp protection FPC4754
The robust rear light protection is suitable for trucks operating in tough conditions.

Working lamp frame end, left-hand and right-hand side FPC4743
Work light at rear end of frame, on left and right-hand side. Controlled with a switch on the door panel.

The bodybuilding process

“Together we can make the best trucks in the world”

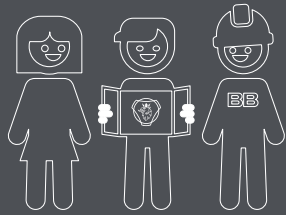

1

The bodybuilding process is a shared process. By involving all stakeholders from the beginning, we secure quality, reduce lead time and eliminate waste.

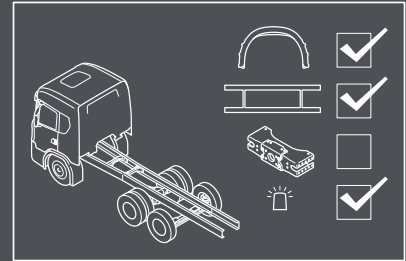

The early stage is very important. Here we make sure the chassis is equipped with the right preparations and has an optimized bodywork interface.

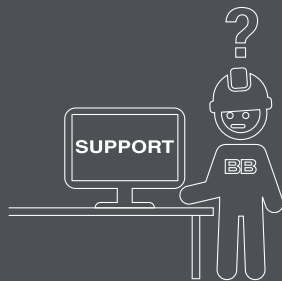

3

Whenever information is required, Scania truck bodybuilder portal has everything you need.

4

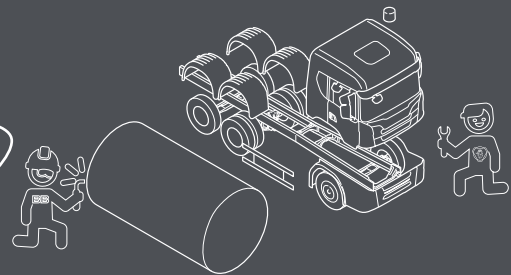

With good planning the chassis and bodywork can be produced in parallel to shorten lead time in the build process.

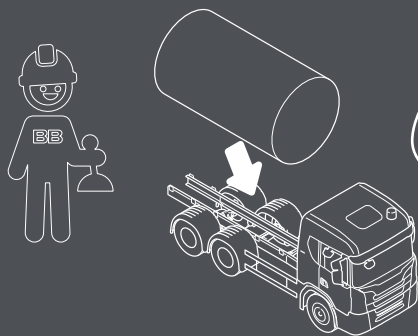

5

When the chassis arrives at the bodybuilder, fitting the bodywork is just plug and play.

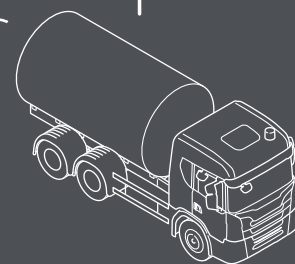
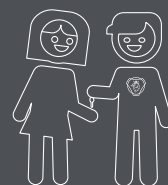

This process ensures that we deliver the highest quality, on time, at the right cost. And the customer will take delivery of the best truck in the world.

Scania CV AB

SE 151 87 Södertälje, Sweden
Telephone +46 8 553 810 00
mail@scania.com
www.scania.com

www.truckbodybuilder.scania.com