

# SCANIA



TIPPER

# BODYBUILDING MADE EASIER!

Tailormade for your application with best preparations available.



## Truck specification

Chassi: G 450 B8x4NZ

Cab: CGI7L

### Beacon FPC1330

Mounted on a robust aluminium bar, the rotating beacon supplies efficient warning light.

### Cable harnesses in cab roof FPC3024

Extra harnesses for bodybuilder installed in cab roof.

### Remote controlled engine start FPC3313

Preparation for engine start (need BCI).

### Instrument panel control lights BB FPC3888

There are many options for the bodywork to provide the driver with information, 8 lamps, sound and display messages in the instrument cluster. The lamps can indicate with different colours.

### Preparation for auxiliary headlamp FPC1854

Preparation for additional headlamps comprises harness-to-harness connectors behind the front grille panel for high headlamp position. This preparation is designed for additional headlamps (incl. direction lights) when the regular headlamps are obscured by front mounted equipment such as a snowplough.

### Headlight protection FPC2021

The headlights are protected by a steel grille.

### Plough brackets (FFU) FPC7663

Snow plough brackets, which includes an upper and a lower bracket. The upper bracket is mounted at the front and is covered in order to meet legal requirements. The lower bracket is supplied clamped to the frame.

### CAN switches FPC6793

Spaces in the instrument panel are reserved for extra switches that are programmed in the BCI control unit.

### Bodybuilder tube across IP C\*

All trucks are supplied with an empty tube inside the instrument panel, dedicated for the bodybuilder.

### Tipper control lever FPC4666

Control lever in the cab for activating the hydraulic valve that raises or lowers the tipper body on the truck.

### Plough control on armrest (FFU) FPC7072

Operation unit with armrest fitted on the driver's seat. The operation unit is equipped with two levers for controlling a snow plough at the front and a snow plough on the side. The float position of the snow ploughs is controlled using two separate switches.

### Preparation working lamp side below cab FPC4742

Preparation for work lights aimed backwards on the left and right-hand sides below the cab. Controlled with a switch on the door panel.

### BB electrical supply 150A continually, 250A max B\*

All trucks are supplied with a dedicated electrical output, conveniently located behind the mudguard of the 1st front axle.

### 3x7 pole electrical preparation from cab FPC2411

Pre-routed cable harness from the bodywork's central electric unit that is terminated with a DIN connector on the frame under the cab. 1, 2 or 3 pieces with 7 poles in each (contains different types of 1,5mm<sup>2</sup>, 2,5mm<sup>2</sup> and CAN cables).

\*Always on truck

### Roof rails FPC1401

"The roof rails are in aluminium which simplifies the fitting of an air deflector, roof rack and other extra equipment."

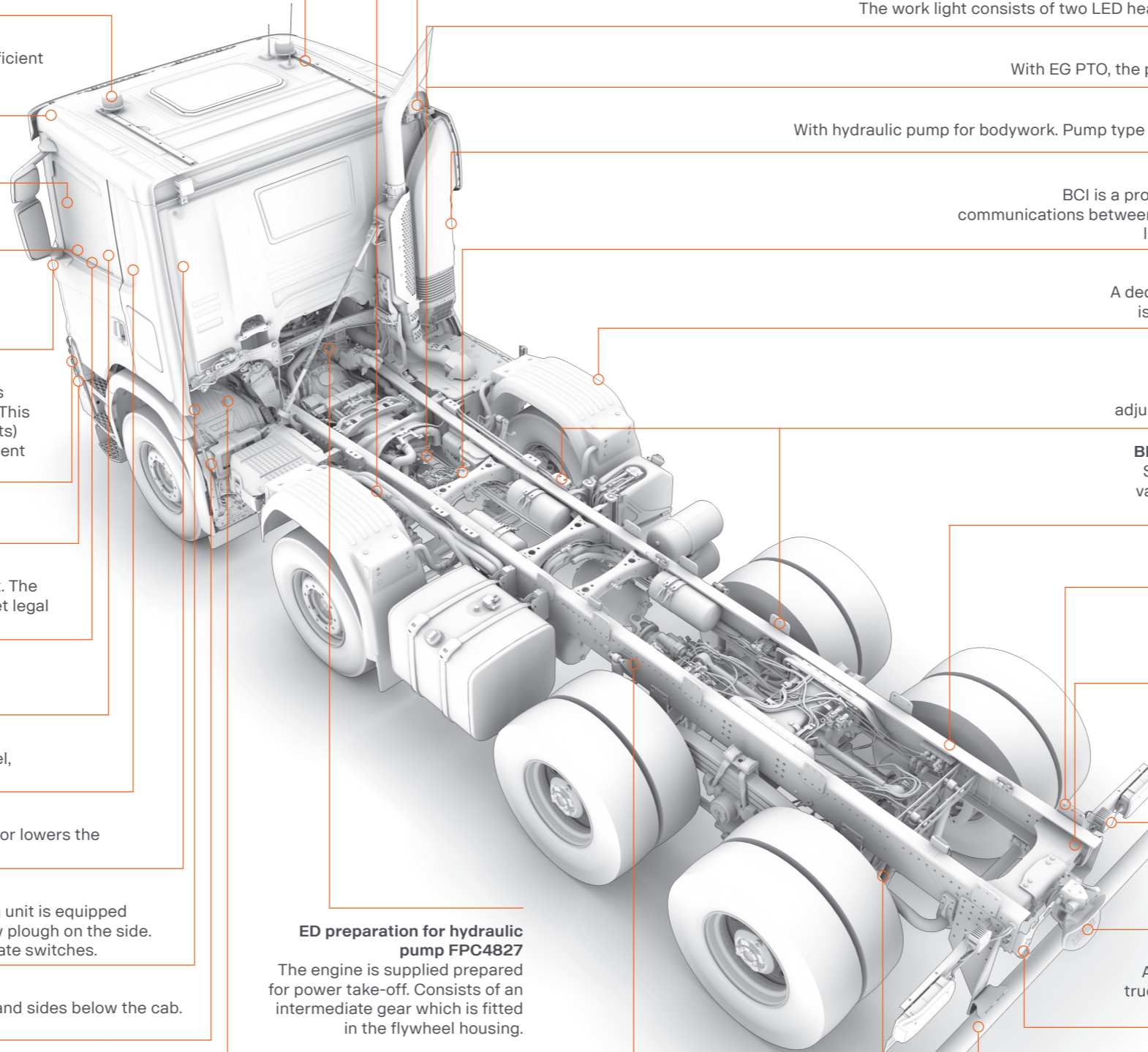

**New routing air and electrical 2nd front axle D\***  
With the new design, Bodybuilder have much more clearance in this area.

**Lowered steering linkage 2nd front axle D\***  
With the new design, Bodybuilder have much more clearance in this area.

**Lowered shock absorber position 2nd front axle D\***  
With the new design, Bodybuilder have much more clearance in this area.

### Working lamps rear wall cab top FPC5900

The work light consists of two LED headlamps fitted on the left and right-hand sides of the rear cab wall.

### EG PTO clutch dependant power take-off FPC6392

With EG PTO, the power take-off can only be used when the clutch pedal is released.

### Hydraulic pump FPC4801

With hydraulic pump for bodywork. Pump type and pump volume can be selected fit different needs/applications.

### BCI Bodywork communication interface FPC5837

BCI is a programmable interface between the truck and bodywork facilitating communications between truck and bodywork. The BCI can be programmed with advanced logics for safety and other operational functionality in the bodywork.

### Air supply inside frame A\*

A dedicated outlet for BB needs of air is included on every chassis. This is the one and only place allowed to connect air supply to bodywork

### Mudguards 2nd front axle FPC4050

The mudguard on the second front axle is height-adjustable. It is supplied from the factory in the highest position, but can be easily adjusted to three different positions to fit with the bodywork and tyres.

### BB brackets (flexible/with holes/for welding) FPC3303, FPC3302

Scania can offer many different body attachment brackets to suit a variety of applications. The bodywork is bolted into the upper row of holes on the bracket.

### Chassis side cover SUP FPC6561

Two different execution available, beam or shirt.

### BB brackets (flexible/with holes/for welding) FPC3412

Scania can offer many different body attachment brackets to suit a variety of applications. The bodywork is bolted into the upper row of holes on the bracket.

### Draw beam incl. coupling FPC1536

Scania drawbeams have hole layouts that allow a drawbeam, under-run protection and body adaptation brackets to be mounted in a wide variety of positions. This makes it unnecessary to drill additional holes in the frame side members.

### Working lamp frame end, left-hand and right-hand side FPC4743

Work light at rear end of frame, on left and right-hand side. Controlled with a switch on the door panel.

### Trailer coupling FPC1540

A towing unit (coupling) is required in order to tow a trailer after the truck. The towing unit is fitted in the truck's drawbeam and both must withstand the forces that arise.

### Air and electrical prep to trailer FPC1556

Trailer connections can be specified in Continental or Nordic versions.

### Rear overhang in 10mm steps FPC1537

Scania can deliver a perfect adapted overhang to every bodywork within 10 mm steps.

### Body work holes in frame, pre punched top row FPC7432

Frame prepared with an upper row of holes. The holes are spaced at 50 millimetres and are used to attach the bodywork to the frame of the truck.

### ED preparation for hydraulic pump FPC4827

The engine is supplied prepared for power take-off. Consists of an intermediate gear which is fitted in the flywheel housing.

### 3x7 poles BB cables (in cab storage RHS) FPC3023

Three 7-pin extension cable. 3 different lengths; 2m, 8m or 12m.

# The bodybuilding process

“Together we can make the best trucks in the world”

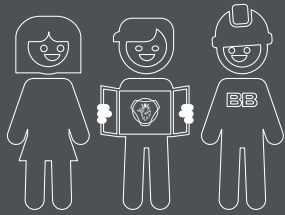

1

The bodybuilding process is a shared process. By involving all stakeholders from the beginning, we secure quality, reduce lead time and eliminate waste.

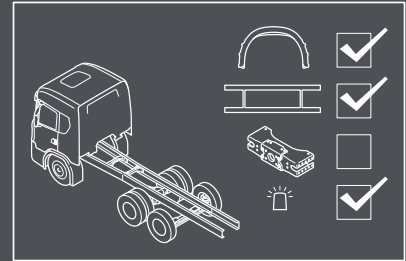

The early stage is very important. Here we make sure the chassis is equipped with the right preparations and has an optimized bodywork interface.

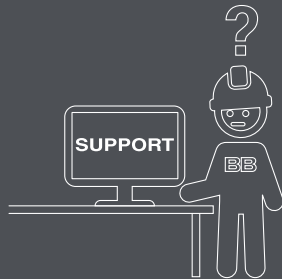

3

Whenever information is required, Scania truck bodybuilder portal has everything you need.

4

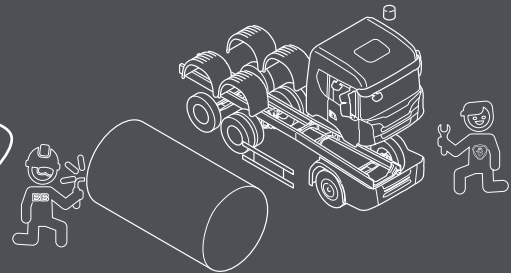

With good planning the chassis and bodywork can be produced in parallel to shorten lead time in the build process.

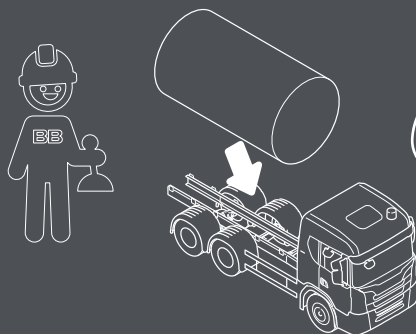

5

When the chassis arrives at the bodybuilder, fitting the bodywork is just plug and play.

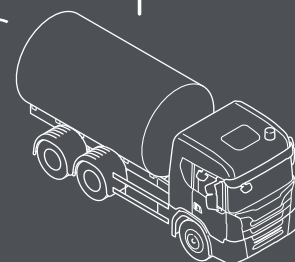
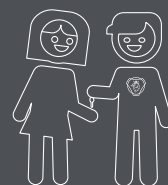

This process ensures that we deliver the highest quality, on time, at the right cost. And the customer will take delivery of the best truck in the world.

## Scania CV AB

SE 151 87 Södertälje, Sweden  
Telephone +46 8 553 810 00  
mail@scania.com  
www.scania.com

[www.truckbodybuilder.scania.com](http://www.truckbodybuilder.scania.com)