

敬啟者：

近期有政府驗車的五軸車輛因第四軸未有安裝泥擋膠(擋泥翼)而未能通過驗車，因此向運輸署查詢，若車輛合乎以下條件(1、2)，則該每個車輪均需要安裝合標準的車輪防護裝置 (車輪沙板及泥擋膠)(見運輸署附件及附圖)，故日後所有新車及已出牌車輛都必須加裝，如車輛未有安裝合適的車輪沙板及泥擋膠可導致驗車不合格，請於製作車輪沙板時注意以上事項，如有疑問可聯絡 Kevin Lee (9845 7319)或 On Chan (6621 8464)。

- 1) 車軸具轉向功能
- 2) 兩車軸輪胎最接近的距離相距多於 300mm

涉及車款及輪軸包括:

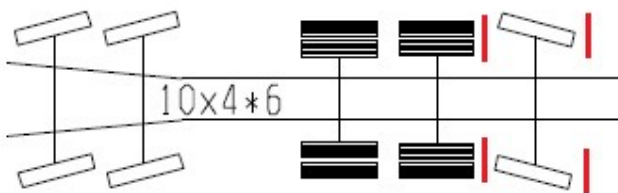

10X4*6 (第四軸、五軸均須安裝泥擋膠(見粗線位置))

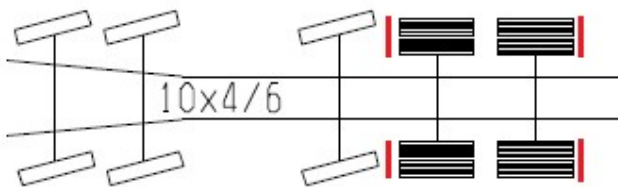

10X4/6 (第三軸、五軸均須安裝泥擋膠(見粗線位置))

此致



陳健安
車輛認證經理
二零一六年五月十九日

“車輪防護裝置”乃車身外殼的一部分、擋泥板及擋泥翼的統稱。

4.12 假如車輛有多條車軸，而在兩條平行車軸上的輪胎又相距超過 300 毫米，則輪胎須分別裝設防護裝置。

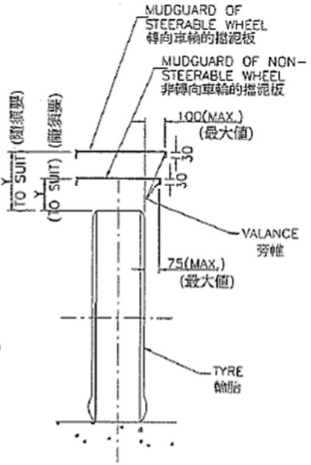
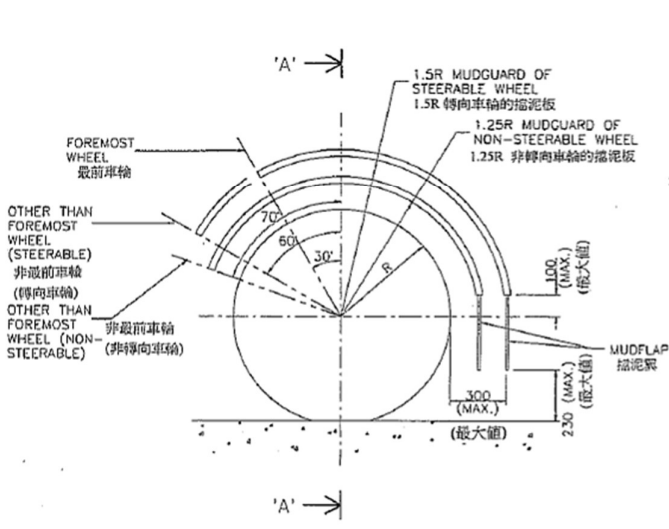

SECTION 'A' - 'A'
'A'-'A' 切面

LEGEND:
Y = DISTANCE BETWEEN TYRE AND MUDGUARD
圖例:
Y = 輪胎與擋泥板距離

NOTES:
1. ALL DIMENSIONS IN mm.
2. THIS DRAWING SHALL BE READ IN CONJUNCTION WITH WHEEL GUARDS SPECIFICATION.
備註:
1. 全部數值以毫米作單位。
2. 閱讀此圖則時，須同時參閱車輪防護裝置的規格。

no.	date	description	initial
REVISION			
designed	H.C. YUEN	08/11/97	
drawn	W.K. LI	12/12/97	
checked	H.C. YUEN	17/12/97	
approved	 Y.W. CHIU		
contract no.			
file no. CT50/131/16-1			
project no.			
圖則名稱 車輪防護裝置 (擋泥板及擋泥翼)規格			
drawing title WHEEL GUARD (MUDGUARDS & MUDFLAPS) SPECIFICATION			
drawing no. 圖則編號	rev.	scale 比例	
SKP3179		NTS	

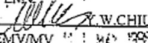
中文翻譯圖
PREPARED BY  H.C. YUEN
APPROVED BY  Y.W. CHIU
SEM/MV '11' 12/1997

VEHICLE EXAMINATION DIVISION
車輛檢驗部
 TRANSPORT DEPARTMENT
香港運輸署

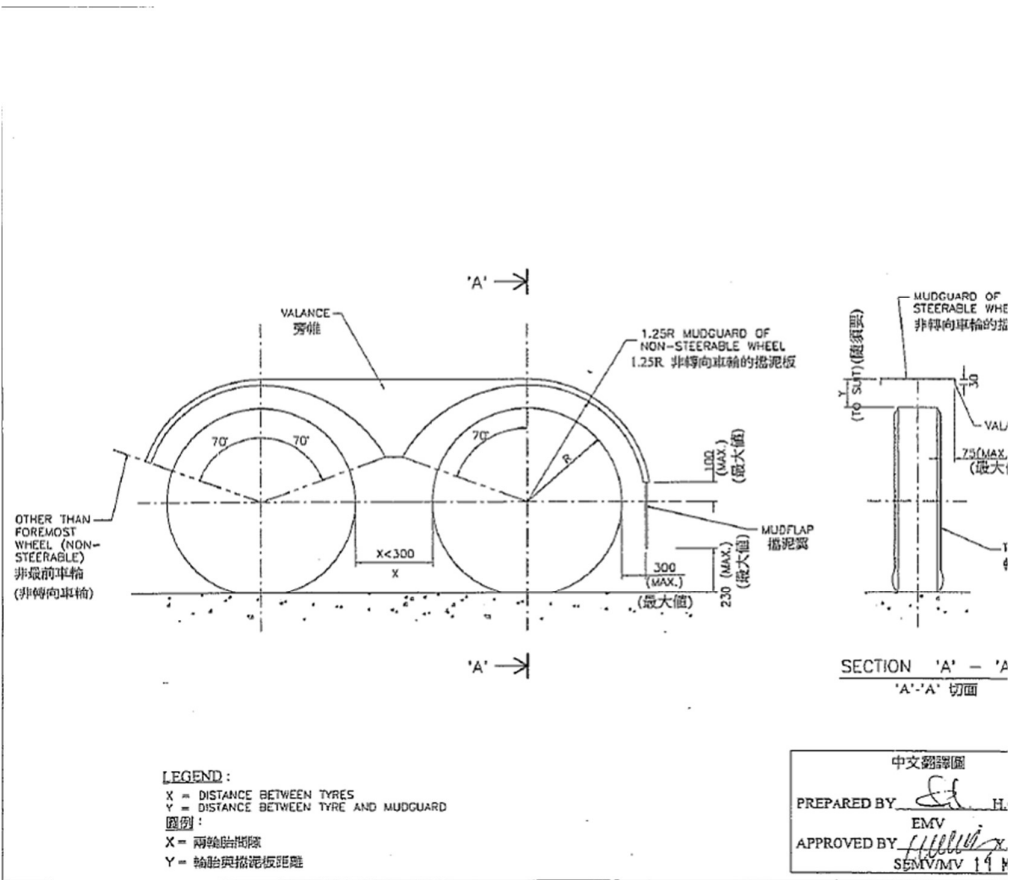



SCANIA
Scania (Hong Kong) Limited

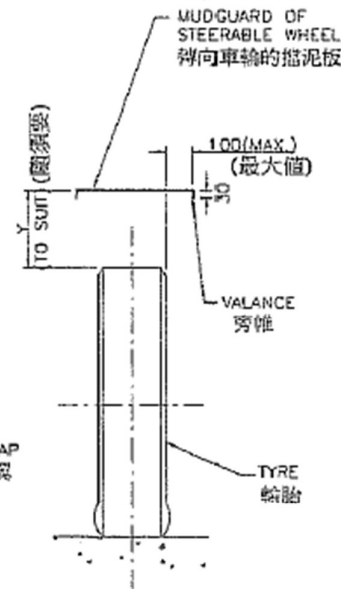
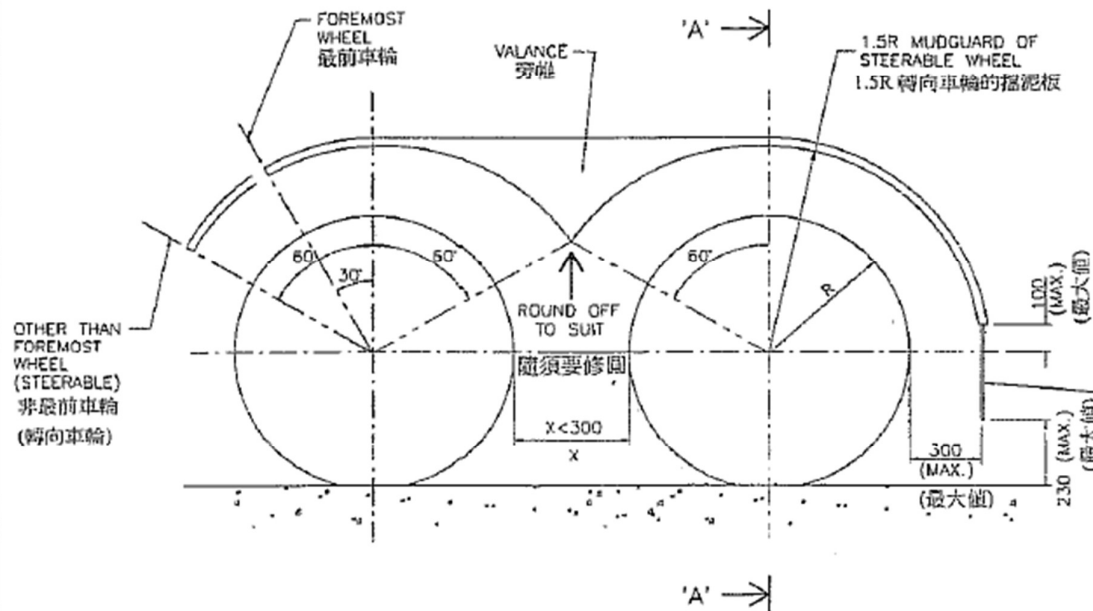

SECTION 'A' - 'A'
'A'-'A' 切面

LEGEND :

X = DISTANCE BETWEEN TYRES
Y = DISTANCE BETWEEN TYRE AND MUDGUARD

圖例 :

X = 兩輪胎間隙
Y = 輪胎與擋泥板距離

NOTES:

1. ALL DIMENSIONS IN mm.
2. THIS DRAWING SHALL BE READ IN CONJUNCTION WITH WHEEL GUARDS SPECIFICATION.

備註:

1. 全部數值以毫米作單位。
2. 閱讀此圖則時，須同時參閱車輪擋泥板規格。

no.	date	description	initial
REVISION			
		name	date
designed		M.C. YUEN	APR 98
drawn		C. K. LI	APR 98
checked		M.C. YUEN	APR 98

approved
SEM/MV 1602 Y.W. CHIU

contract no.

file no. C150/131/46-1

project no.

圖則名稱
多軸(可轉向軸)車輛的
擋泥板及旁帷規格

drawing title
MUDGUARDS & VALANCE
SPECIFICATIONS FOR MULTI-AXLE
(STEERABLE) VEHICLE

drawing no.	rev.	scale
圖則編號 SKP 31793		比例 NTS

中文翻譯圖

PREPARED BY H.C. YUEN

EMV
APPROVED BY Y.W. CHIU
SEM/MV 17 MAY 1998

VEHICLE EXAMINATION DIVISION
車輛檢驗部

TRANSPORT DEPARTMENT
HONG KONG
香港運輸署