



<https://truckbodybuilder.scania.com> (log in for access)

June 20, 2024

Below you will find the latest information that is important to know when bodybuilding on a Scania vehicle.

For Scania contact in bodybuilding issues, see:

<https://bodybuilder.scania.com/trucks/en/help/market-contacts.html>

BATTERY CHARGING OR JUMP START

All vehicles with electrical system generation 7 (FPC9742B) are equipped with a battery data module which monitoring the batteries and measures the current through the negative terminal. If bypassed, there is a risk that the vehicle power will be disconnected without prior warning.

Never connect directly to the negative terminal at the batteries when charging or jump starting.

For vehicles equipped with Battery jump start interface these connections shall be used whenever temporary connecting to the 24V batteries is needed for instance charging 24V batteries or jump starting.

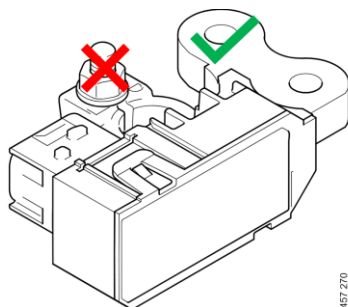

457 270

If Battery jump start interface is not available on the vehicle, battery charging or jump start connection may be connected at the batteries and then it is important to connect to the metal plate where the earth connection is connected.

CAMERAS IN SCANIA'S DIGITAL DRIVER ENVIRONMENT

Information for moving the camera included in the legal requirement as well as fitting additional cameras is now available in the instructions.

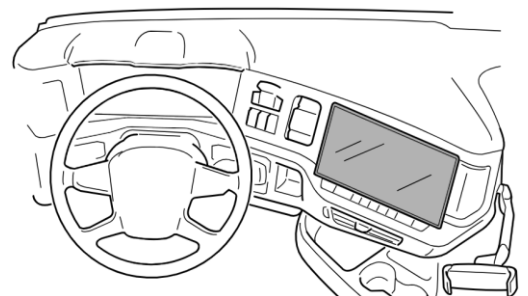

<https://bodybuilder.scania.com/trucks/camerasmartdash> (login required)

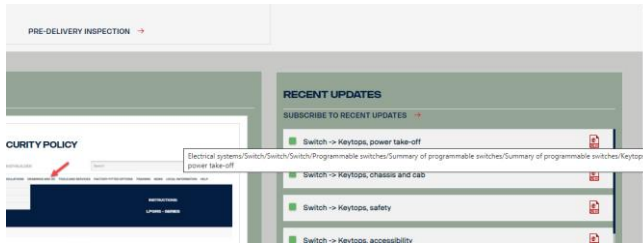

RECENT UPDATES

On the bodybuilder portal first page under 'Recent updates' you find the changes done in the 'LPGR-series' (Instructions), 'Use and responsibility, legal requirements' (Requirements) and 'Product data' (Drawings and 3D) sections. By clicking the link you see the full text of the affected section. By hover on the text you see the search way in the structure.

NEW T FLIP-FLOP INTRODUCED IN BICT

All CAN pushbuttons in the BICT logics for vehicles with new electrical system generation 7 (FPC9742B) are of non-latched type. For latched operation of the pushbutton a flip-flop is required in the BICT logic diagram. There are two different kind of flip-flops available for this purpose in the electrical system generation 7 trucks: T flip-flop (introduced earlier) and T flip-flop for switches (newly introduced for electrical system generation 7 trucks)

The new type of flip-flop requires an acknowledgement (input F) after activation request (input P) from the actuator connected to the output in order to sustain active state.

Both type of the flip-flops do also provide a possibility for persistent state activation. This means in practice that the flip-flop will remember it's state even after the ignition has been switched off in the vehicle.

Below some examples of how the flip-flops can be utilized in a BICT logic diagram. More information can be found in the operator's function description embedded in the BICT application.

